

Diaphragm seal

clamp connection per DIN 32676, ISO 2852

Type series DL3../DL4..



Application area

- Food industry
- Pharmaceutical industry
- Biotechnology

Features

- Flush-mounted separating diaphragm of stainless steel, laser welded
- Volume optimised diaphragm base
- Clamp connection per DIN 32676 with EHEDG certificate
- System fillings for different applications
- Measuring device connection:
 - directly welded
 - directly screwed
 - with temperature decoupler
 - with capillary

Options

- Labom REconnect quick coupling device for easy and safe separation and connection of diaphragm seal systems. Available with a wide range of pressure gauges and pressure transmitters; Type series MK1000, see data sheet DB_D6-022
- Certificates
 - Material certificate acc. to EN 10204-3.1
- Electropolishing (wetted parts)
- Hygienic design with advanced surface quality
- Special materials upon request

Application

Suitable for mounting to bourdon tube pressure gauges and pressure transmitters. The diaphragm seal with clamp connection is used mainly for dead-zone free pressure measurement.

Technical data

Constructional design

Basic body:	Volume reduced diaphragm base Material: stainless steel mat.-no. 1.4404/1.4435 (316L)
Diaphragm:	Flat diaphragm
Material wetted parts:	Diaphragm: Stainless steel mat.-no. 1.4435 (316L) Further materials upon request Basic body: Stainless steel mat.-no. 1.4404/1.4435 (316L)

Process connection

Design:	Clamp connection per:
	<ul style="list-style-type: none"> ■ DIN 32676 ■ ISO 2852

Nominal pressure/nominal width: See table

Sealing are not included in the scope of delivery.

Measuring device connection

See order details.

Material stainless steel mat.-no. 1.4301 (304)

System filling

See order details; further upon request.

Further details about pressure transmission fluids see general technical information TA_038.

Hygienic design

The surface roughness of the wetted parts made of stainless steel are executed according to EHEDG Doc.8 and ASME BPE SF3.
In case of choosing the additional feature HY, we guarantee the following surface roughness values:

Diaphragm foil:	Ra ≤ 0.38 µm
Laser welds:	Ra ≤ 0.76 µm
Turned parts:	Ra ≤ 0.76 µm

Further versions of hygienic design upon request.

Temperature error

In order to optimise the system we provide a detailed error calculation upon request.

Weight

See table.

Installation instructions

For diaphragm seals with clamp design an operation outside the permissible nominal pressure range is only permitted when using suitable clamping rings. Please note DIN 32676 on temperature resistance.

Further information about diaphragm seals see general technical information TA_031.

Flame arrester MF21xx for connection of measuring devices to zone 0 see data sheet D6-025.

Measuring device connection

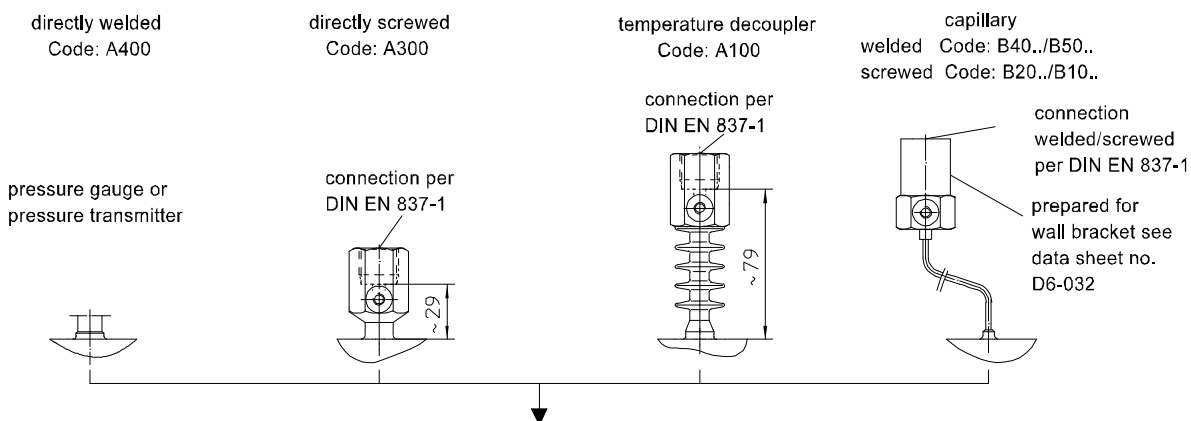

Dimensions

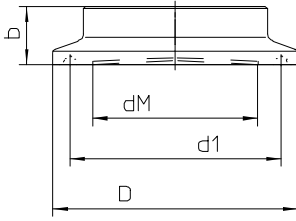

Mounting example

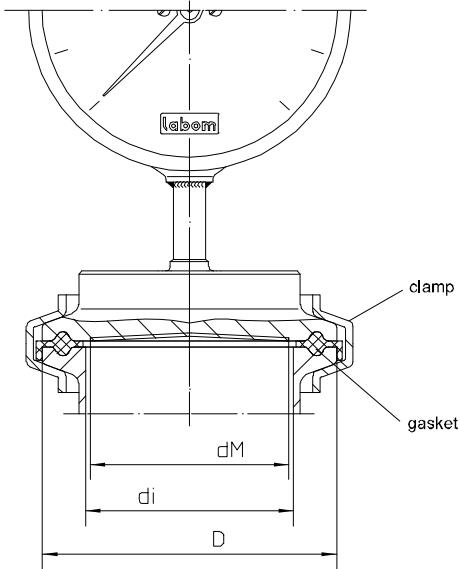

Clamp connection per DIN 32676 model A (metric) for pipes per EN 10357 (DIN 11850)

DN mm	PN bar	dM mm	d1 mm	di mm	b mm	D mm	weight approx. kg
15	25	15.5	27.5	16	15	34	0.1
20	25	15.5	27.5	20	15	34	0.1
25	25	22.6	43.5	26	14	50.5	0.3
32	25	27	43.5	32	12	50.5	0.3
40	25	34	43.5	38	12	50.5	0.3
50	16	46	56.5	50	14	64	0.4
65	16	65	83.5	66	14	91	0.8

Clamp connection per DIN 32676 model B (OD/ISO) for pipes per DIN EN ISO 1127

DN mm	PN bar	dM mm	d1 mm	di mm	b mm	D mm	weight approx. kg
21.3	25	17.5	43.5	18.1	12	50.5	0.3
26.9	25	22.6	43.5	23.7	12	50.5	0.3
33.7	25	27	43.5	29.7	12	50.5	0.3
42.4	25	34	56.5	38.4	14	64	0.4
48.3	16	40	56.5	44.3	14	64	0.4
60.3	16	51	70.5	56.3	14	77.5	0.5
76.1	10	70	83.5	72.1	14	91	0.8

Clamp connection per DIN 32676 model C (Tri-Clamp) for pipes per ASME BPE

DN inch	PN bar	dM mm	d1 mm	di mm	b mm	D mm	weight approx. kg
3/4"	25	15.5	20.2	15.75	15	25	0.2
1"	25	22.6	43.5	22.1	14	50.5	0.3
1 1/2"	25	34	43.5	34.8	12	50.5	0.3
2"	16	46	56.5	47.5	14	64	0.4
2 1/2"	16	51	70.5	60.2	14	77.5	0.5
3"	16	70	83.5	72.9	14	91	0.8

Clamp connection per ISO 2852 for pipes per ISO 2037

DN mm	PN bar	dM mm	d1 mm	di mm	b mm	D mm	weight approx. kg
25	16	22.6	43.5	22.6	14	50.5	0.3
38	16	34	43.5	35.6	12	50.5	0.3
51	16	46	56.5	48.6	14	64	0.4
63.5	16	51	70.5	60.3	14	77.5	0.5
76.1	16	70	83.5	72.9	14	91	0.8

Order details

Diaphragm seal clamp connection per ISO 2852, DIN 32676, Type series DL3 . . . / DL4 . . .					
				Clamp socket-Ø [mm]	Membran-Ø dM [mm]
DL4080	clamp per DIN 32676 ^{1,2} model A (metric) for pipes per EN 10357 (DIN 11850)	DN 15	PN 25	34	15.5
DL4090		DN 20	PN 25	34	15.5
DL4100		DN 25	PN 25	50.5	22.6
DL4200		DN 32	PN 25	50.5	27
DL4300		DN 40	PN 25	50.5	34
DL4400		DN 50	PN 16	64	46
DL4500		DN 65	PN 16	91	65
DL3040	clamp per DIN 32676 ^{1,2} model B (OD/ISO) for pipes per DIN EN ISO 1127	DN 21.3	PN 25	50.5	17.5
DL3140		DN 26.9	PN 25	50.5	22.6
DL3240		DN 33.7	PN 25	50.5	27
DL3340		DN 42.4	PN 25	64	34
DL3440		DN 48.3	PN 16	64	40
DL3540		DN 60.3	PN 16	77.5	51
DL3640		DN 76.1	PN 16	91	70
DL3030	clamp per DIN 32676 ^{1,2} model C (Tri-Clamp) for pipes per ASME BPE	DN 3/4"	PN 25	25	15.5
DL3130		DN 1"	PN 25	50.5	22.6
DL3230		DN 1 1/2"	PN 25	50.5	34
DL3330		DN 2"	PN 16	64	46
DL3430		DN 2 1/2"	PN 16	77.5	51
DL3530		DN 3"	PN 16	91	70
DL3100	clamp per ISO 2852 for pipes per EN ISO 2037	DN 25	PN 16	50.5	22.6
DL3200		DN 38	PN 16	50.5	34
DL3300		DN 51	PN 16	64	46
DL3400		DN 63.5	PN 10	77.5	51
DL3500		DN 76.1	PN 10	91	70
HY	surface roughness	Hygienic version as per EHEDG Doc.8 and ASME BPE SF3			
A400 .	measuring device connection	directly	welded		
A300 .			screwed G1/2		
A100 .		with temperature decoupler	screwed G1/2		
B40 . .			with capillary	welded	
B20 . .		screwed G1/2			
B50 . .		with capillary and stainless steel protective tube	welded		
B10 . .			screwed G1/2		
11		capillary length	1 m		
12			1.6 m		
13			2.5 m		
14			4 m		
21			5 m		
15			6 m		
23			7 m		
16	8 m				
17	10 m				
9	others				
7	material	wetted parts stainless steel mat.-no. 1.4435 (316L)			
L22	system filling ³	<u>pressure transmission fluid</u>	<u>temperature range</u> ⁴		
L23		synthetic oil, free of silicone FD1, standard	-10...140 °C		
L15		synthetic oil, free of silicone FD1, pls. specify max. temperature	-40...230 °C		
		glycerine/water FGW	-30...110 °C		
Additional features (to be indicated in case of need, only)					
W1020	material certificate acc. to EN 10204-3.1, wetted parts				
W4035	electropolishing of wetted parts				

Order code (example): DL3200 - A4007 - L22 - ...

¹ EHEDG certified only in connection with hygienic design (order code option HY)

² EHEDG certificate valid only if gaskets are used that are listed in the "EHEDG position paper"

³ for more detailed information about pressure transmission fluids see TA_038.
Please state temperature range to allow an accurate calculation of the system.

⁴ max. media temperature for pressures > 0 bar rel.